

# *N*-particle Dynamics of Polarizable Stockmayer-type Molecules

FRANZ J. VESELY

*I. Physikalisches Institut der Universität Wien, Strudlhofgasse 4, A-1090 Wien*

Received May 1, 1976; revised September 16, 1976

Expressions are given for the potential energy, the forces, and the virial in a computer ensemble of  $N$  polarizable point dipoles. An iterative scheme for use in molecular dynamics calculations is tested.

## 1. INTRODUCTION

In molecular dynamics calculations on systems of dipolar molecules [1–4] polarization effects have generally been disregarded, or treated only in an ad hoc manner by the introduction of “effective” dipole moments [3, 4]. The only exception is a tentative study by Berendsen [5] on a rather complicated system, namely a polarizable BNS [3] water model. In the new and very promising central force model of Lemberg and Stillinger [6] polarizability is implicitly accounted for, but it is difficult to discern its effects from those of other model parameters.

While the effective dipole approach, with suitably chosen effective moments, may yield a good approximation to the correct equilibrium properties, it cannot a priori be expected to account equally well for the dynamics and the dielectric properties of a polarizable dipole system.

By way of a systematic approach to this problem one should start out by studying a very simple “Stockmayer-type” system consisting of spherical molecules (e.g., Lennard–Jones) with embedded polarizable point dipoles. Since the spherical symmetric part of the potential is irrelevant for our purposes, only the dipolar part is considered in the following sections.

The numerical calculation of the many-particle dynamics of polarizable dipole molecules is complicated by the fact that the convenient assumption of pairwise additive interactions is no longer valid. It is therefore necessary at each time step first to compute all induced dipoles in a self-consistent way before one can determine all the quantities that appear in the equations of motion and in the molecular expressions for the thermodynamic functions.

In Section 2 expressions are given for the potential energy, the force on one particle, and the virial in a system of  $N$  polarizable point dipoles. These formulas are then modified by long-range correction terms, so as to be applicable in computer experiments on pseudoinfinite samples. Specific schemes for calculating the induced dipoles for a given configuration are discussed, and the rate of convergence of an iterative

procedure is tested in Section 3. The performance of the iterative method in an actual molecular dynamics calculation is studied in Section 4. In the last section prospects and problems of molecular dynamics calculations on such a system are discussed.

## 2. POTENTIAL ENERGY, FORCES, AND VIRIAL

Consider a configuration of  $N$  point dipoles with a set of spatial coordinates  $\mathbf{r} \equiv \{\mathbf{r}_1 \cdots \mathbf{r}_N\}$ , rigid dipole vectors  $\mathbf{p} \equiv \{\mathbf{p}_1 \cdots \mathbf{p}_N\}$ , and a constant polarizability  $\alpha$ . The induced dipoles are then given by

$$\Delta \mathbf{p}_i = \alpha \mathbf{E}_i = \alpha \sum_j \bar{T}_{ij} (\mathbf{p}_j + \Delta \mathbf{p}_j) = \alpha \sum_j \bar{T}_{ij} \mathbf{p}_j^*, \quad (1)$$

where  $\mathbf{E}_i$  is the local electrostatic field at point  $i$ ,

$$\bar{T}_{ij} = \frac{1}{r_{ij}^3} \left[ \frac{3\mathbf{r}_{ij}\mathbf{r}_{ij}}{r_{ij}^2} - 1 \right], \quad (2)$$

$$\bar{T}_{ii} = 0,$$

is the dipole-dipole tensor, and  $\mathbf{p}_j^*$  denotes the total (resultant) dipole vector of particle  $j$ .

The total potential energy of the system is given by

$$\begin{aligned} U_{\text{tot}}(\mathbf{r}, \mathbf{p}) &= -\frac{1}{2} \sum_i \sum_j \mathbf{p}_i^* \bar{T}_{ij} \mathbf{p}_j^* + (1/2\alpha) \sum_i \Delta \mathbf{p}_i^2 \\ &= -\frac{1}{2} \sum_i \mathbf{p}_i \mathbf{E}_i, \end{aligned} \quad (3)$$

where the term  $(1/2\alpha) \sum_i \Delta \mathbf{p}_i^2 = (\alpha/2) \sum_i \mathbf{E}_i^2 = U_{\text{pol}}$  denotes the work of formation of the induced dipoles. It is important to note that the generalized function

$$U(\mathbf{z}, \mathbf{r}, \mathbf{p}) = -\frac{1}{2} \sum_i \sum_j (\mathbf{p}_i + \mathbf{z}_i) \bar{T}_{ij} (\mathbf{p}_j + \mathbf{z}_j) + (1/2\alpha) \sum_i \mathbf{z}_i^2 \quad (4)$$

for given  $\mathbf{r}$  and  $\mathbf{p}$  is minimized by the choice

$$\mathbf{z}_i = \Delta \mathbf{p}_i(\mathbf{r}, \mathbf{p}) = \alpha \sum_j \bar{T}_{ij} (\mathbf{p}_j + \Delta \mathbf{p}_j), \quad i = 1, \dots, N.$$

By definition of  $U$  this minimum coincides with  $U_{\text{tot}}(\mathbf{r}, \mathbf{p})$

$$U[\Delta \mathbf{p}(\mathbf{r}, \mathbf{p}), \mathbf{r}, \mathbf{p}] \equiv U_{\text{tot}}(\mathbf{r}, \mathbf{p}).$$

For the force acting on particle  $k$  we have, in an obvious notation,

$$K_k^\nu = -\frac{\partial}{\partial x_k^\nu} U_{\text{tot}} - \sum_i \sum_\beta \frac{\partial z_i^\beta}{\partial x_k^\nu} \left[ \frac{\partial}{\partial z_i^\beta} U(\mathbf{z}, \mathbf{r}, \mathbf{p}) \right]_{\mathbf{z}=\Delta \mathbf{p}(\mathbf{r}, \mathbf{p})}. \quad (5)$$

Due to the minimum property of  $U(\mathbf{z}, \mathbf{r}, \mathbf{p})$  the second term vanishes, and we get

$$K_k^\gamma = \sum_j K_{kj}^\gamma = \sum_j \sum_\alpha \sum_\beta p_k^{*\alpha} T_{kj}^{\alpha\beta, \gamma} p_j^{*\beta} \quad (6)$$

with

$$T_{kj}^{\alpha\beta, \gamma} = \frac{3}{r_{kj}^5} (\delta^{\beta\gamma} x_{kj}^\alpha + \delta^{\gamma\alpha} x_{kj}^\beta + \delta^{\alpha\beta} x_{kj}^\gamma) - \frac{15}{r_{kj}^7} x_{kj}^\alpha x_{kj}^\beta x_{kj}^\gamma. \quad (7)$$

The virial of our system for a given configuration is

$$W = -\frac{1}{2} \sum_k \sum_j \sum_\gamma K_{kj}^\gamma x_{kj}^\gamma = -\frac{3}{2} \sum_k \sum_j \mathbf{p}_k^* \bar{T}_{kj} \mathbf{p}_j^* = 3(U_{\text{tot}} - U_{\text{pol}}). \quad (8)$$

Energy, force, and virial, together with the torque on particle  $k$ ,

$$\mathbf{N}_k = \mathbf{p}_k \times \mathbf{E}_k \quad (9)$$

are all that is needed for a molecular dynamics calculation on the system under consideration. The above expressions, however, are not yet suitable for numerical work on a “pseudoinfinite” molecular dynamics system which consists of periodic boxes containing typically  $N \approx 100$ – $1000$  molecules. In computer experiments on molecules with short-ranged potentials the interactions of a given particle with the others are explicitly calculated only up to a certain cutoff distance, while the long-range part is dealt with by way of a simple correction term. Due to the slow  $(1/r^3)$  radial decay of the dipole–dipole potential the long-range correction is rather large in this case and must be constructed with some care. In the framework of rigid dipole calculations two methods have been proposed to deal with this problem: one is the Ewald–Kornfeld summation method, in which the volume containing  $N$  dipoles is regarded as a basic crystallographic element in an infinite “crystal”; the interactions of a given dipole with all the others within the basic cell and with all the periodic images of all dipoles is then expressed in terms of two rapidly converging series [7, 8]. The suspicion, however, that this method overemphasizes the artificial periodicity of the computer ensemble has not yet been disproved [8]. Moreover, the evaluation of the said series is still a rather tedious task. (Smith and Perram [9] have recently proposed a numerical method which may serve to improve things in this respect.) The other method of correcting for the long-range interactions has been introduced by Barker and Watts in their Monte Carlo work on water [10]. Drawing from the Onsager–Debye theory of dielectrics, it treats the surroundings of the cutoff sphere as a dielectric continuum (with properly estimated dielectric constant  $\epsilon_0$ ) which is polarized by the total dipole moment of the truncation sphere. This polarization then creates an additional “reaction field”  $\mathbf{R}_i$  within the sphere around particle  $i$ , and it is the interaction of the dipole  $i$  with this reaction field which is hoped to properly account for the interaction with the further-out regions of our system. If we regard the reaction field as an instantaneous effect, this concept can also be applied to a molecular dynamics

ensemble of dipoles [11]. The generalization to polarizable dipoles presents no serious problem: The reaction field within the cutoff sphere of radius  $r_{co}$  is

$$\mathbf{R}_i = a \sum_{j \in S_i} \mathbf{p}_j^*, \quad \text{where } a = \frac{2(\epsilon_0 - 1)}{2\epsilon_0 + 1} \frac{1}{r_{co}^3} \quad (10)$$

and where the sum is over all dipoles within the cutoff sphere, including the central dipole  $i$ . The resultant field  $\mathbf{E}_i$  is then

$$\mathbf{E}_i = a \sum_{j \in S_i} \bar{T}_{ij} \mathbf{p}_j^* + \mathbf{R}_i = \sum_{j \in S_i} (\bar{T}_{ij} + a) \mathbf{p}_j^* \quad (11)$$

and the induced dipoles are now

$$\Delta \mathbf{p}_i = \alpha \sum_{j \in S_i} (\bar{T}_{ij} + a) \mathbf{p}_j^* \quad (12)$$

The total potential energy is

$$U_{tot} = -\frac{1}{2} \sum_i \mathbf{p}_i \mathbf{E}_i = -\frac{1}{2} \sum_i \sum_{j \in S_i} \mathbf{p}_i (\bar{T}_{ij} + a) \mathbf{p}_j^* \quad (13)$$

The force on the central particle  $i$  is not changed by the reaction field, which by construction is homogeneous within the cutoff sphere

$$K_i^\gamma = \sum_{j \in S_i} \sum_{\alpha} \sum_{\beta} p_i^* T_{ij}^{\alpha\beta, \gamma} p_j^{*\beta} \quad (14)$$

If we take (13) to be a good approximation to the exact potential energy, we can simply insert (13) into (8) to get for the virial

$$\begin{aligned} W &= -\frac{3}{2} \sum_i \sum_{j \in S_i} \mathbf{p}_i (\bar{T}_{ij} + a) \mathbf{p}_j^* - (3/2\alpha) \sum_i \Delta \mathbf{p}_i^2 \\ &= -\frac{3}{2} \sum_i \sum_{j \in S_i} \mathbf{p}_i (\bar{T}_{ij} + a) \mathbf{p}_j^* - (3\alpha/2) \sum_i \mathbf{E}_i^2. \end{aligned} \quad (15)$$

The torque on particle  $i$  is, of course, given by

$$\mathbf{N}_i = \mathbf{p}_i \times \mathbf{E}_i = \mathbf{p}_i \times \left[ \sum_{j \in S_i} (\bar{T}_{ij} + a) \mathbf{p}_j^* \right]. \quad (16)$$

### 3. CALCULATION OF THE INDUCED DIPOLES

The actual calculation of the induced dipoles  $\Delta \mathbf{p}_i$  (or, equivalently, of the local fields  $\mathbf{E}_i$ ) for given  $\mathbf{r}$  and  $\mathbf{p}$  can be achieved in two different ways.

(a) Algebraically, by solving the equations

$$\Delta \mathbf{p}_i = \alpha \sum_{j \in S_i} (\bar{T}_{ij} + a) \mathbf{p}_j + \alpha \sum_{j \in S_i} (\bar{T}_{ij} + a) \Delta \mathbf{p}_j \quad (12a)$$

or, formally,

$$\Delta \mathbf{p} = \mathcal{A} \mathbf{p} \quad (17)$$

with

$$\mathcal{A} = \alpha [1 - \alpha(\mathcal{T} + a)]^{-1} (\mathcal{T} + a).$$

Considering that  $\mathcal{A}$  is a  $3N \times 3n$ -matrix, with typical values of  $N \approx 100$  and  $n \approx 50$  (number of particles within a cutoff sphere), it was not attempted to carry through such a calculation; however,  $\mathcal{A}$  is highly symmetrical and Eq. (17) may well be treatable.

(b) In a more simple and intuitive way, by seeking an iterative solution to (17). As starting values one may choose  $\Delta \mathbf{p}_i = 0$ . Another choice, which is more suitable for use in molecular dynamics calculations, would be  $\mathbf{p}_i^*(t) = \mathbf{p}_i^*(t - \Delta t)$ , the resultant dipole vector at the previous time step.

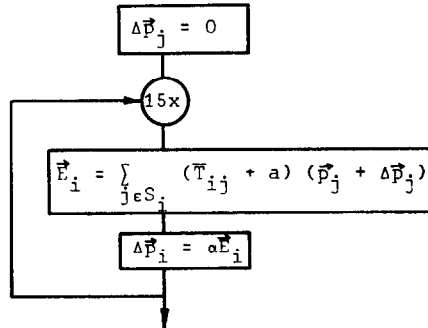

FIGURE 1

The convergence properties of the simple iterative procedure shown in Fig. 1 was tested, using a random configuration of 108 Stockmayer particles. The “rigid Stockmayer” molecular dynamics program used to create this configuration was made available to me by D. Adams. State parameters pertaining to the test configuration were the following: reduced density  $\tilde{\rho} (\equiv (N/V) \sigma^3) = 0.7$ , reduced temperature  $\tilde{T} (\equiv T(k/\epsilon)) = 1.19$  and reduced dipole moment  $\tilde{p} (\equiv p/(\epsilon \sigma^3)^{1/2}) = 1$ . Always using the same rigid dipole directions and relative positions of the particles 15 iterations were performed for each of the six states  $\tilde{\rho} = 0.6/0.7/0.8$ ,  $\tilde{p} = 1$ ,  $\tilde{\alpha} (\equiv (\alpha/\sigma^3)) = 0.05/0.10$ . In addition, the rather extreme case  $\tilde{\rho} = 0.8$ ,  $\tilde{p} = 1$ ,  $\tilde{\alpha} = 0.15$  was studied in an analogous way. Taking the Lennard-Jones parameters of argon ( $\epsilon = 1.653 \cdot 10^{-14}$  erg,

$\sigma = 3.405 \text{ \AA}$ ) as an example,  $\tilde{p} = 1$  is equivalent to a dipole moment of 0.808 D, and  $\tilde{\alpha} = 0.05$  would imply  $\alpha = 1.97 \cdot 10^{-24} \text{ cm}^3$ . After each iteration  $n$  the values of

$$S_1(n) = \sum_{i=1}^N |\mathbf{E}_i(n) - \mathbf{E}_i(n-1)|^2$$

and

$$S_2(n) = \sum_{i=1}^N \mathbf{E}_i^2(n)$$

were printed. The quantity  $R_E(n) = S_1(n)/S_2(n)$  was used as a measure for the accuracy achieved after step  $n$  (it should be understood that  $n = 0$  denotes the initial step). It is evident from Fig. 2 that  $\ln R_E(n)$  becomes an approximately linear function of  $n$  after a few iterations, and that the rate of descent depends weakly on density and strongly on the polarizability  $\tilde{\alpha}$ . For the different states under study the number of iterations needed to achieve an accuracy of  $R_E = 10^{-4}$  are listed in Table I. In the "unphysical" case  $\tilde{\alpha} = 0.15$  no convergence was achieved within 20 iterations. As cross-checks have shown, the results given in Fig. 2 and Table I are well reproduced when different rigid dipole configurations are used.

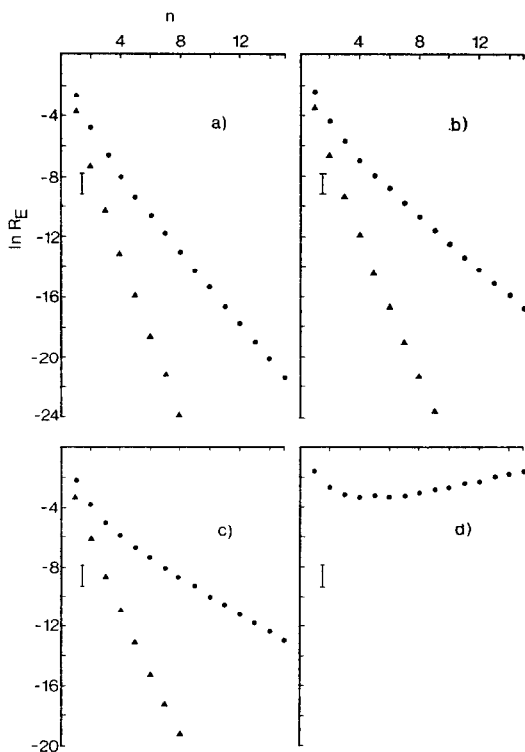

FIG. 2. Logarithm of relative error of the field after  $n$  iterations; (a)  $\tilde{p} = 0.6$ , (b)  $\tilde{p} = 0.7$ , (c) and (d)  $\tilde{p} = 0.8$ ; triangles:  $\tilde{\alpha} = 0.05$ , dots:  $\tilde{\alpha} = 0.10$  ( $\tilde{\alpha} = 0.15$  in case (d)). The vertical bar denotes the region  $10^{-4} < R_E < 4 \cdot 10^{-4}$ .

TABLE I  
 Number of iterations necessary to reach  $R_E < 10^{-4}$  if  $\Delta p_i (n = 0) = 0$ ;  
 limiting slope  $k_\infty$  of  $\ln R_E$

$\bar{\rho}$	$\bar{\alpha} = 0.05$		$\bar{\alpha} = 0.10$	
	<i>n</i>	$k_\infty$	<i>n</i>	$k_\infty$
0.6	3	-2.76	5	-1.19
0.7	3-4	-2.35	7	-0.85
0.8	4	-2.13	9	-0.61

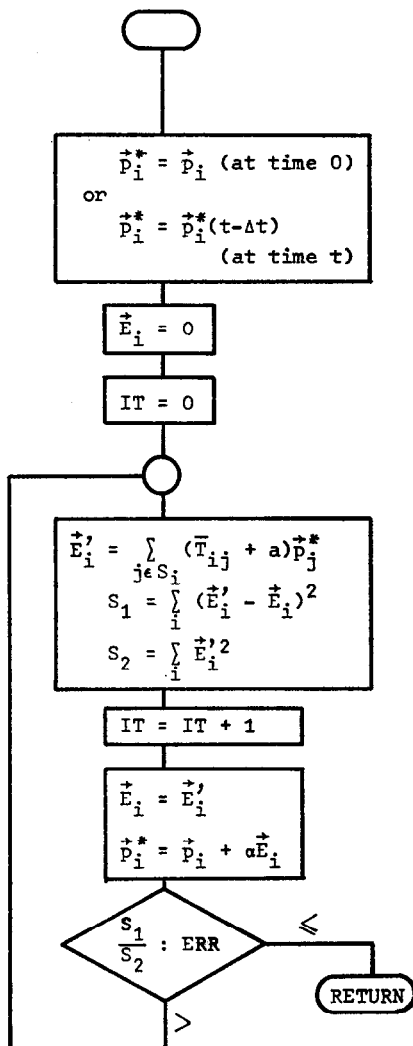

FIGURE 3

The formulas given in Section 2 together with the iterative procedure provide the means for computer experiments on polarizable dipolar molecules. In the framework of an actual molecular dynamics program the loop of Fig. 1 is to be replaced by the subroutine of Fig. 3.

We have seen that the iteration scheme converges quite rapidly for reasonable values of  $\tilde{\alpha}$ , even if we take  $\Delta\mathbf{p}_i = 0$  as initial values. Convergence will be much faster within a molecular dynamics run where we have a better estimate on  $\Delta\mathbf{p}_i$ , or  $\mathbf{p}_i^*$ , to start with. The proximity of  $\mathbf{p}_i^*(t - \Delta t)$  to  $\mathbf{p}_i^*(t)$ , and therefore the speed of convergence to some required accuracy, will depend on the size of the time step, on temperature, on mass and moment of inertia of the particles, etc. We can obtain an estimate on the number of iterations needed if we assume that the typical change in  $\mathbf{E}_i$  during one time step will not exceed, say, 2% of the average value of  $|\mathbf{E}_i|$  (otherwise the time step would be too large anyway). Further assuming, for the sake of argument, that all local fields are independent, we have

$$|\Delta_i| \equiv |\mathbf{E}_i(t) - \mathbf{E}_i(t - \Delta t)| \leq 0.02(1/N) \sum_i |\mathbf{E}_i| \leq 0.02 \left( (1/N) \sum_i \mathbf{E}_i^2 \right)^{1/2}$$

or

$$\Delta_i^2 \leq 0.0004(1/N) \sum_i \mathbf{E}_i^2.$$

Thus,

$$R_E(1) = \frac{S_1(1)}{S_2(1)} = \frac{\sum_i \Delta_i^2}{\sum_i \mathbf{E}_i^2} \leq 0.0004.$$

It is evident from Fig. 2 that in this situation only one (for  $\tilde{\alpha} = 0.05$ ) or two (for  $\tilde{\alpha} = 0.10$ ) iterations are necessary to improve the accuracy to  $R_E \leq 10^{-4}$ .

Experience with preliminary molecular dynamics calculations has shown that the above estimates are in fact too pessimistic: Values of  $R_E(1)$  are typically much lower, in some cases even below  $10^{-4}$ .

It should be mentioned that other cutoff conditions than  $R_E \leq 10^{-4}$  could be used. In order to calculate the dynamics of *each* particle accurately to 1% a suitable condition would be

$$\max_{i=1, \dots, N} \frac{|\mathbf{E}_i(n) - \mathbf{E}_i(n-1)|}{|\mathbf{E}_i(n)|} \leq 10^{-2}$$

but the rapid convergence renders such considerations unimportant, and the simple prescription given in Fig. 3 should suffice in all practical applications.

#### 4. PERFORMANCE TESTS

The iteration subroutine of Fig. 3 was incorporated in Adams' molecular dynamics program, and the performance of the method was tested in a series of trial runs. These calculations, as well as the static tests of Section 3, were done on the Vienna



Interuniversity Computing Center's CDC-CYBER 74, and required approximately 1 sec per iteration. The time step used was  $\Delta t = 0.016(m\sigma^2/40\epsilon)^{1/2}$ , and the moment of inertia was  $I = m\sigma^2/40$ .

Starting from a specific "thermalized" configuration, the polarizable Stockmayer system was followed for 100 time steps, the cutoff accuracy being set to  $R_E \leq 10^{-4}$ . It was found that for the state  $\tilde{\rho} = 0.7$ ,  $\tilde{T} = 1.158$ ,  $\tilde{\beta} = 1$ ,  $\tilde{\alpha} = 0.05$  the mean number of iterations per time step was only slightly larger than 1, and the actual mean accuracy was  $\langle R_E \rangle = 0.34 \cdot 10^{-4}$ .

In a parallel run using the same starting configuration of the particles the cutoff condition on  $R_E$  was removed, and full 10 iterations were performed at each time step. This resulted in a virtually infinite accuracy ( $R_E(10) \simeq 0.5 \cdot 10^{-13}$ ) and a corresponding increase in computing time.

The total (kinetic plus potential) energy of the system was monitored and compared for the two computations. Figures 4a and 4b show the energy and its deviation from the "infinite accuracy" value for every fifth time step. (The relatively large energy fluctuations as well as the slight overall trend are due to "jumps" in the potential energy whenever a dipole enters or leaves the cutoff sphere of another dipole.) It is evident that the condition  $R_E \leq 10^{-4}$ , requiring typically 1-2 iterations per time step, is perfectly sufficient, so that a good approximation to the "real" phase space trajectory

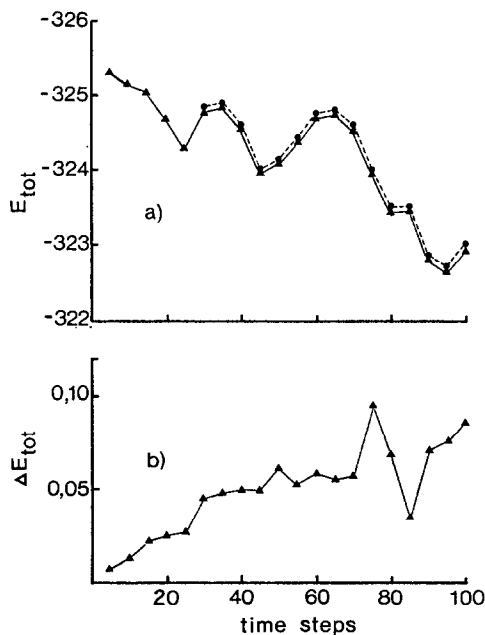

FIG. 4. (a) Total energy  $E_{tot}$  of the  $N = 108$  polarizable Stockmayer system with  $\tilde{\beta} = 1$ ,  $\tilde{\alpha} = 0.05$ ,  $\tilde{\rho} = 0.7$ ,  $\tilde{T} = 1.15$ . Energy is given in units of  $\epsilon$  for every fifth time step; straight lines between points are for convenience. Dots denote the "infinite accuracy" run with 10 iterations, triangles are for  $\langle R_E \rangle = 3.4 \cdot 10^{-5}$ . (b) Deviation of  $E_{tot}$  from the "infinite accuracy" value.

of the polarizable Stockmayer system can be achieved at only moderate expense in computer time.

Having assessed the accuracy of the iterative method, a longer computation was performed to calculate internal energy and pressure of the polarizable Stockmayer system. State parameters were  $\bar{\rho} = 0.7$ ,  $\bar{T} = 1.144$ ,  $\bar{p} = 1$ ,  $\bar{\alpha} = 0.05$ , and  $\epsilon_0$  (for the reaction field) = 4. In addition, the simple Stockmayer ( $\bar{\alpha} = 0$ ) system was studied using the same values of  $\bar{\rho}$ ,  $\bar{p}$  and  $\epsilon_0$ ; mean temperature was  $\bar{T} = 1.189$  in this case. Since in molecular dynamics calculations the temperature is not a fixed parameter, the results had to be corrected for temperature to be comparable with literature values. The internal energies and pressures given in Ref. [12] suggest that the variation with temperature of these properties stems mainly from the Lennard-Jones interaction. Making this assumption and constructing a quadratic fit to literature values of  $U^{LJ}/N\epsilon$  and  $p^{LJ}/\rho kT$  at  $\bar{T} = 0.75$ , 1.15, and 1.35, one derives, at  $\bar{T} = 1.15$ , the gradients  $d(U^{LJ}/N\epsilon)/d\bar{T} = 1.025$  and  $d(p^{LJ}/\rho kT)/d\bar{T} = 3.674$ . These were used for a linear correction, the deviations of temperature from the desired value being small in both calculations.

Results are given in Table II. Statistical errors are estimated to be  $\pm 0.05$  for  $U/N\epsilon$  and  $\pm 0.10$  for  $p/\rho kT$ . Literature values given for comparison are Padé approximations to perturbation theoretical results and are taken from McDonald [12].

TABLE II

Preliminary results for thermodynamic properties of the  $N = 108$  polarizable Stockmayer system  
 $\bar{\rho} = 0.7$ ,  $\bar{T} = 1.15^a$

	No. of steps	$\frac{U}{N\epsilon}$ (md)	$\frac{U}{N\epsilon}$ (tpt)	$\frac{p}{\rho kT}$ (md)	$\frac{p}{\rho kT}$ (tpt)
$\bar{p} = 1, \bar{\alpha} = 0$	1200	-5.59	-5.69	-0.04	0.12
$\bar{p} = 1, \bar{\alpha} = 0.05$	972	-5.80	-5.80	-0.09	-0.04

<sup>a</sup> (md) = results of molecular dynamics calculations; (tpt) = results of thermodynamic perturbation theory taken from Ref. [12].

The comparison is encouraging, though not yet conclusive. Deviations are larger for the simple Stockmayer system than in the polarizable case, and longer runs will be necessary to clear this point.

## 5. DISCUSSION AND OUTLOOK

The static tests described in Section 3 and the preliminary molecular dynamics runs of Section 4 have shown that the  $N$ -particle dynamics of a simple polarizable dipole system can be studied in the computer without excessive cost in computer time. In

fact, it may be sufficient in some cases to calculate the local fields at time  $t$  by the formula

$$\mathbf{E}_i(t) = \sum_{j \in S_i} (\bar{T}_{ij}(t) + a) \mathbf{p}_j^*(t - \Delta t),$$

without performing any iterations at all.

It may be desirable to extend the considerations of Section 2 to cover nonisotropic and environment-dependent polarizabilities. Nowhere have we made use of the scalar property of  $\alpha$ , so the formulas of Section 2 apply even if  $\alpha$  is a tensor quantity. Moreover, all the expressions remain treatable if we try to include the influence of the interparticle interactions (and especially head-on collisions) on the polarizability, which can be done by introducing an indexed  $\alpha_i$  that may vary between different particles.

For large polarizabilities and temperatures a polarization catastrophe may occur. The condition for this is

$$r_{ij} < (2\alpha)^{1/3}.$$

During a collision with a relative kinetic energy of, say,  $100\epsilon$ , two Lennard-Jones molecules approach each other to a distance of  $r_{\min} = 0.67\sigma$ . The "catastrophe condition" on  $\alpha$  is then  $\alpha > 0.15\sigma^3$ , or, again taking argon as an example,  $\alpha > 5.92 \cdot 10^{-24} \text{ cm}^3$ . Since  $\alpha$  is typically in the range  $(1 - 3) \cdot 10^{-24} \text{ cm}^3$ , a breakdown of this kind is due to occur at very high temperatures only.

#### ACKNOWLEDGMENTS

I am deeply indebted to Professor K. Singer for all his hospitality and courtesy. Special thanks are also due to D. Adams whose efficient molecular dynamics program has been very helpful to me. A travel grant supplied by Professor F. Kohler is gratefully acknowledged.

#### REFERENCES

1. G. D. HARP AND B. J. BERNE, *Phys. Rev. A* **2** (1970), 975-996.
2. B. J. BERNE AND G. D. HARP, *Advan. Chem. Phys.* **17** (1970), 63-227.
3. A. RAHMAN AND F. H. STILLINGER, *J. Chem. Phys.* **55** (1971), 3336-3359.
4. F. H. STILLINGER AND A. RAHMAN, *J. Chem. Phys.* **57** (1972), 1281-1292.
5. H. J. C. BERENDSEN AND G. A. VAN DER VELDE, Report of CECAM workshop on Molecular Dynamics of Water, 1972.
6. H. L. LEMBERG AND F. H. STILLINGER, *J. Chem. Phys.* **62** (1975), 1677-1690.
7. H. KORNFIELD, *Z. Phys.* **22** (1924), 27-41.
8. V. M. JANSOONE, *Chem. Phys.* **3** (1974), 78-86.
9. E. R. SMITH AND J. W. PERRAM, *Molecular Phys.* **30**, No. 1 (1975), 31-36.
10. J. A. BARKER, Report of CECAM workshop on Molecular Dynamics of Water, 1972; J. A. BARKER AND R. O. WATTS, *Molecular Phys.* **26** (1973), 789-792; R. O. WATTS, *Molecular Phys.* **28**, (4)(1974), 1069-1083.
11. D. ADAMS, private communication.
12. I. R. McDONALD, *J. Phys. C* **7** (1974), 1225-1236.